

Schematic Diagram

Models:GJH07AF-K3RNB9D GJH09AF-K3RNB9D GJH09AF-K3RND2A

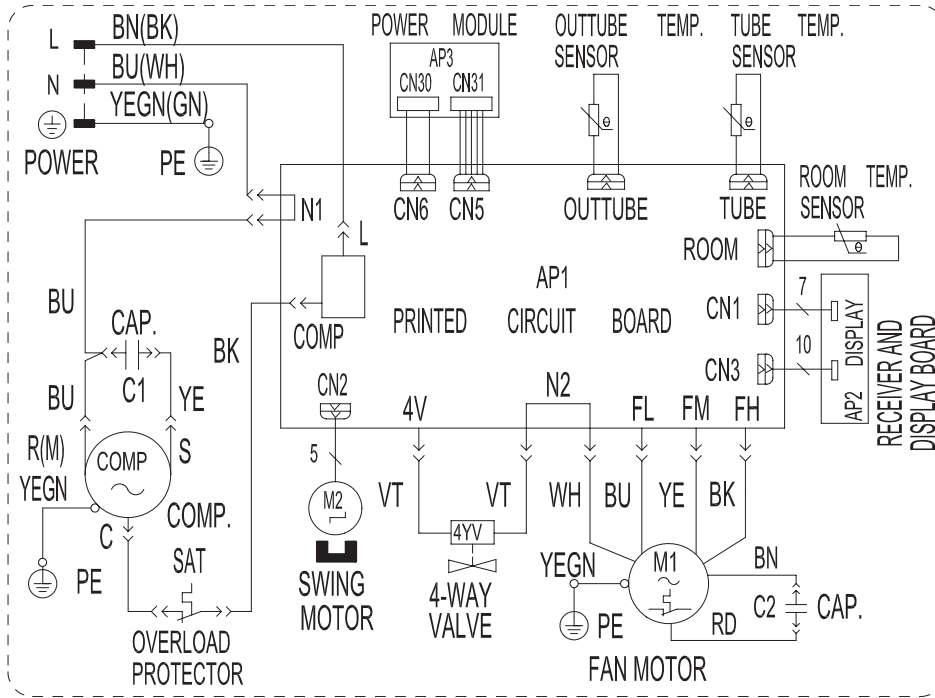

Models:GJH07AF-K3RND2A GJH12AD-K3RNB9D GJH12AD-K3RND2A GJH18AC-K3RNB9D GJH18AC-K3RND2A

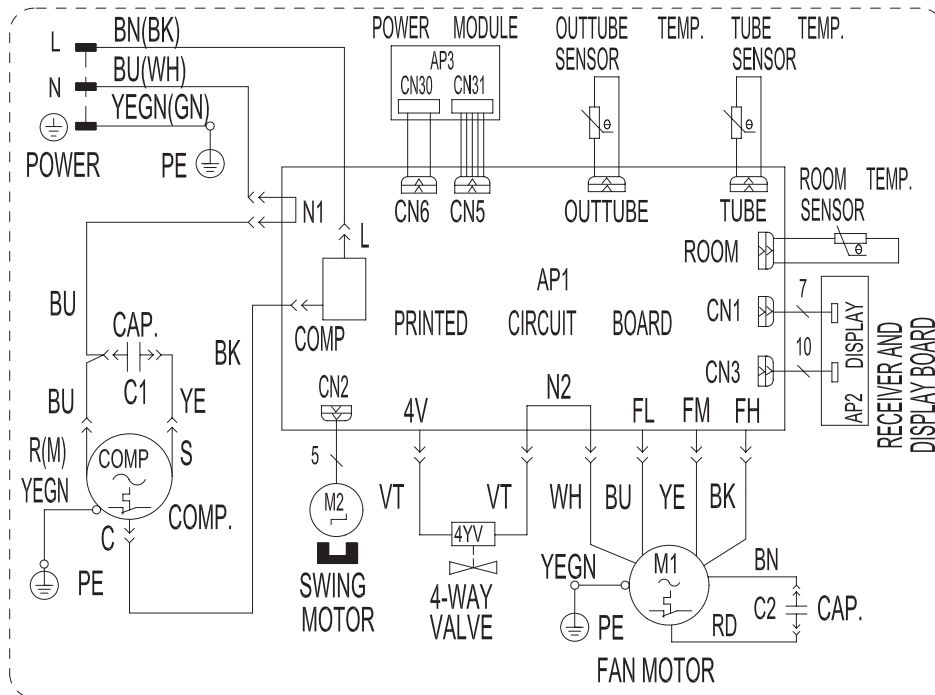

Model:GJH21AC-K3RNB9D GJH21AC-K3RND2A

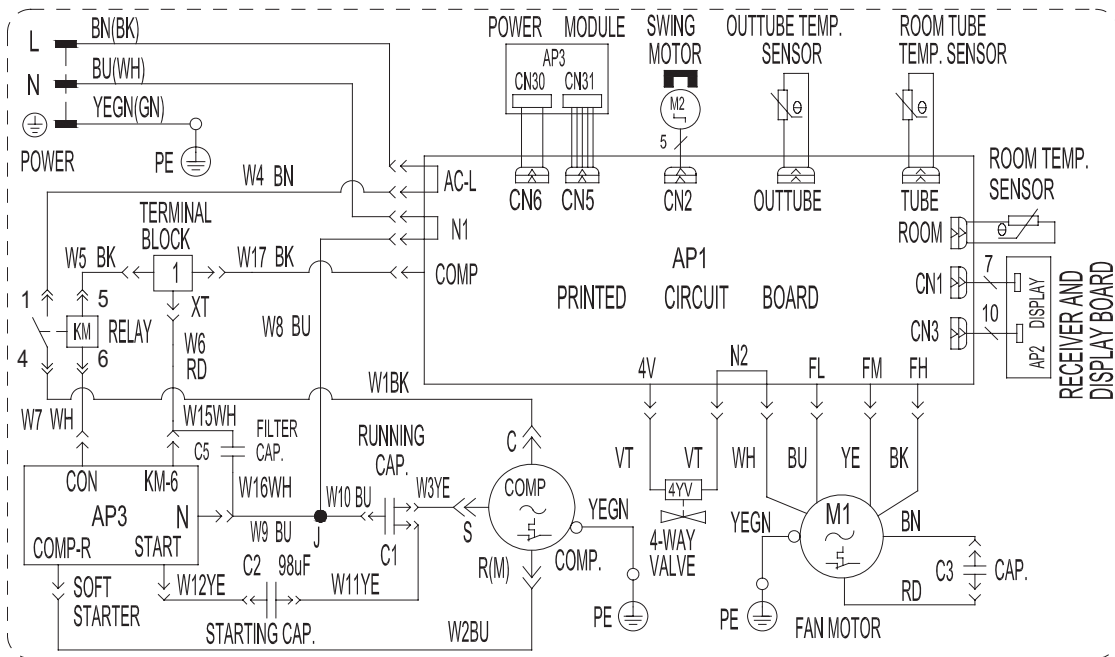

These circuit diagrams are subject to change without notice, please refer to the one supplied with the unit.